

## Overhead Gym



## Tummy Time Fun

### **WARNING**

To prevent entanglement injury, never place gym in a crib or playpen. Never add strings, ties or other products to the gym.

Please keep this instruction sheet for future reference, as it contains important information.

Requires four “AA” (LR6) **alkaline** batteries for operation (not included).

Adult assembly is required.

Tool required for battery installation: Phillips screwdriver (not included).

# Assembled Parts

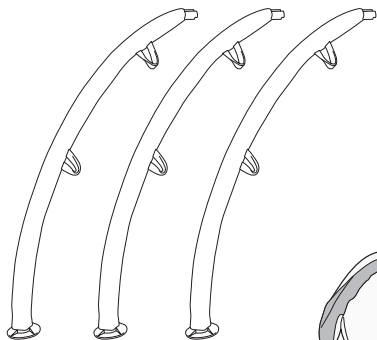

**3 Arches**



**Sun Toy**



**Butterfly Teether**



**Bolster**

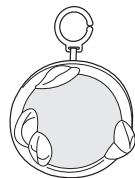

**Mirror**

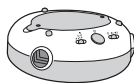

**Hub**



**Snail Toy**



**Frog Toy**

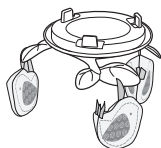

**Mobile**



**Owl Toy**

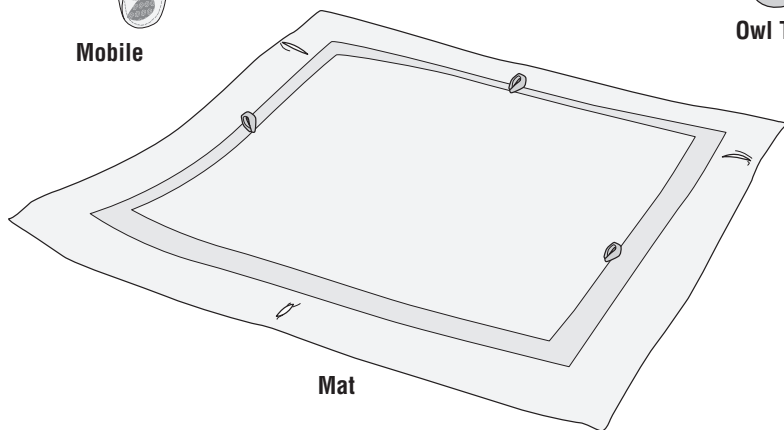

**Mat**

## Battery Installation

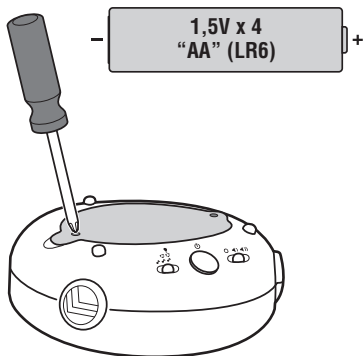

- Locate the battery compartment door on the hub.
- Loosen the screws in the battery compartment door with a Phillips screwdriver and remove the door.
- Insert four "AA" (LR6) **alkaline** batteries.

***Hint:** We recommend using **alkaline** batteries for longer battery life. Battery life is shorter when using Music, Lights and Motion mode.*

- Replace the battery compartment door and tighten the screws with a Phillips screwdriver. Do not over-tighten.
- If this toy begins to operate erratically, you may need to reset the electronics. Slide the power/volume switch off and then back on.
- When sound/lights/motion from this toy become faint or stop, it's time for an adult to change the batteries.



- Protect the environment by not disposing of this product with household waste (2002/96/EC). Check your local authority for recycling advice and facilities.

## Battery Safety Information

In exceptional circumstances, batteries may leak fluids that can cause a chemical burn injury or ruin your product. To avoid battery leakage:

- Do not mix old and new batteries or batteries of different types: alkaline, standard (carbon-zinc) or rechargeable (nickel-cadmium).
- Insert batteries as indicated inside the battery compartment.
- Remove batteries during long periods of non-use. Always remove exhausted batteries from the product. Dispose of batteries safely. Do not dispose of this product in a fire. The batteries inside may explode or leak.
- Never short-circuit the battery terminals.
- Use only batteries of the same or equivalent type, as recommended.
- Do not charge non-rechargeable batteries.
- Remove rechargeable batteries from the product before charging.
- If removable, rechargeable batteries are used, they are only to be charged under adult supervision.

## Care

### Mat and Bolster

- Wash in cold water on the gentle cycle. Do not use bleach. Tumble dry low.

### Arches, Hub, Mobile, Mirror, Teether and Toys

- Wipe the surface with a clean cloth dampened with a mild soap and water solution. Do not use bleach.
- Do not immerse hub.

# Consumer Information

**CONSUMER ASSISTANCE**  
1-800-432-5437 (US & Canada)  
1300 135 312 (Australia)  
**service.fisher-price.com**

---

Fisher-Price, Inc., 636 Girard Avenue, East Aurora, NY 14052.  
Hearing-impaired consumers: 1-800-382-7470.

---

**Outside the United States:**

Canada: Mattel Canada Inc., 6155 Freemont Blvd.,  
Mississauga, Ontario L5R 3W2; [www.service.mattel.com](http://www.service.mattel.com).

Great Britain: Mattel UK Ltd, Vanwall Business Park,  
Maidenhead SL6 4UB. Helpline: 01628 500303.  
[www.service.mattel.com/uk](http://www.service.mattel.com/uk)

Mattel Europa B.V., Gondel 1, 1186MJ Amstelveen, Nederland.

Australia: Mattel Australia Pty. Ltd., 658 Church Street,  
Locked Bag #870, Richmond, Victoria 3121 Australia.

New Zealand: 16-18 William Pickering Drive,  
Albany 1331, Auckland.

## FCC Statement (United States Only)

This equipment has been tested and found to comply with the limits for a Class B digital device, pursuant to Part 15 of the FCC Rules. These limits are designed to provide reasonable protection against harmful interference in a residential installation. This equipment generates, uses and can radiate radio frequency energy and, if not installed and used in accordance with the instructions, may cause harmful interference to radio communications. However, there is no guarantee that interference will not occur in a particular installation. If this equipment does cause harmful interference to radio or television reception, which can be determined by turning the equipment off and on, the user is encouraged to try to correct the interference by one or more of the following measures:

- Reorient or relocate the receiving antenna.
- Increase the separation between the equipment and receiver.
- Consult the dealer or an experienced radio/TV technician for help.

Note: Changes or modifications not expressly approved by the manufacturer responsible for compliance could void the user's authority to operate the equipment. This device complies with Part 15 of the FCC Rules. Operation is subject to the following two conditions: (1) this device may not cause harmful interference and (2) this device must accept any interference received, including interference that may cause undesired operation.

## ICES-003

- This Class B digital apparatus complies with Canadian ICES-003.
- Operation is subject to the following two conditions: (1) this device may not cause harmful interference and (2) this device must accept any interference received, including interference that may cause undesired operation.

## NMB-003

- Cet appareil numérique de la classe B est conforme à la norme NMB-003 du Canada.
- L'utilisation de ce dispositif est autorisée seulement aux conditions suivantes : (1) il ne doit pas produire de brouillage et (2) l'utilisateur du dispositif doit être prêt à accepter tout brouillage radioélectrique reçu, même si ce brouillage est susceptible de compromettre le fonctionnement du dispositif.

# Setup

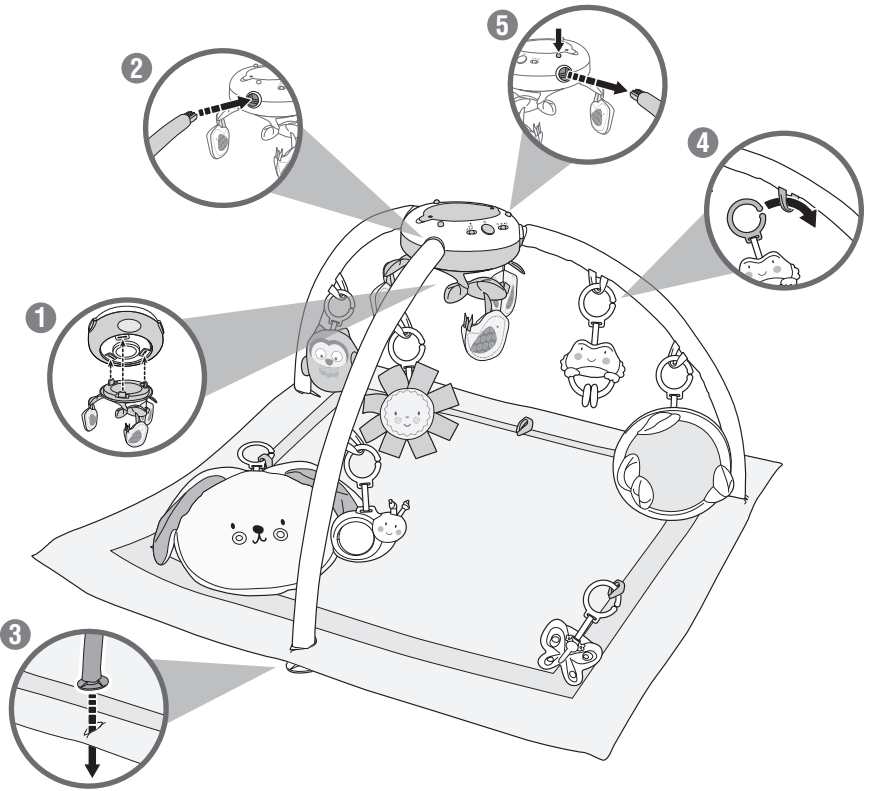

- 1 Fit the tabs on the mobile into the slots in the hub. Push to **"snap"** in place. This is a permanent assembly.
- 2 Insert and **"snap"** each arch into the sockets in the hub.
- 3 Lay the mat on a flat surface with the decorated side up. Insert the end of each arch through the holes on the outside of the mat.
- 4 Hang the toys from loops on the arches or the mat.
- 5 To remove the arches from the hub, simply press the button on the hub near each arch socket.

# Motorized Mobile with Music & Lights!



**Power/Volume  
Switch**

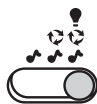

**Mode  
Switch**



**Song Select  
Button**

- Slide the power/volume switch on the hub to ON with low volume ◀▶, or ON with high volume ▶▶).
- Slide the mode switch to:
  - 🎵 **Music Only**
  - 🎵🎶 **Music and Motion**
  - 🎵💡 **Music Lights and Motion**
- Press the song select button on the top of the hub to play a song. Press the button again to change the song. Music plays for up to 20 minutes with each press!
- When you are finished playing with this toy, slide the power/volume switch OFF ○.